



5CB Coaxial Passive Point Source

[Wide Dispersion, Dome Tweeter]



APPLICATIONS

Front Fill
Cinema / Theater
FX Speakers
Convention Centers
Educational Facilities
Night Clubs
Studio Monitors
Nearfield Monitors
Broadcast Monitors

FEATURES

Coaxial, Horn-loaded
Two-Way Passive
LF Device: 5 in. (127mm)
HF Device:
0.75 in. (19.1mm) Dome Tweeter
120° H x 120° V Coverage
Integral Rigging Points
Durable Polyurea Coating
NL4 SpeakON Connectors
& 2-Pos. Terminal Strip

GENERAL DESCRIPTION

Clair Brothers 5CB loudspeaker has been designed as a hi-fidelity, small-format point source speaker. The frequency response is exceptionally wide bandwidth and high output for a device of its size, 85Hz–20,000Hz (-10dB), allowing for use for speech and music reproduction. The 5CB features 5" coaxial transducer with a 3/4" dome tweeter with 120° conic coverage.

The 5CB features a SpeakON In/thru connectors as well as a single two position terminal strip. An internal passive crossover network provides frequency domain filtering allowing for exceptionally clear output with remarkable coherence through the crossover region. The 5CB is well-suited for distributed systems, area fill applications with full PA systems just as it is equally well equipped to stand alone as a main speaker in a smaller environment. The 5CB's smooth response and low distortion figures also make it an excellent reference monitor, particularly when combined with its complement subwoofer, the 12Sx.

Mechanical & Accessories:

Like its series companions, the 5CX and 8CX, the 5CB offers a seemingly unlimited number of ways to rig and/or mount utilizing a family of mounting accessories. The 5CB has (4) integral mounting points (M10 x 1.5 thread). The accessories include yoke mounting brackets for both vertical and horizontal mounting positions

as well as tilt adaptors to enable pan and tilt in either configuration. The brackets also have a companion pole mount socket to allow unrestrained pan and tilt when used as a pole mount speaker. Additional accessories include: threaded stud plates, pipe clamp mounts, chain rigging points, VESA tilt mount and array mode top-bar plates.

The 5CB is well-suited for down-firing applications, such as large convention centers or high ceiling commercial spaces. In particular, the pair of mounting points available on each panel of the cabinet are spaced at the same spacing as slots on standard Unistrut hardware, allowing for exceptional compatibility in commercial integration projects. Please contact Clair Brothers for more information regarding coverage area planning and simulation.

OPTIONS & ACCESSORIES

5CX-P-70 – Similar Model w/Compression Driver HF
12Sx – Companion Subwoofer
Vertical and Horizontal Yoke Mounting Brackets w/
Tilt Adaptors
Threaded Stud Plates (M10, 3/8-16, 1/2-13) Pipe
Clamp Mount
Chain Rigging Points
VESA Tilt Mount
Array Mode Top-Bar Plates

5CB Coaxial Passive Point Source

[Wide Dispersion, Dome Tweeter]



AUDIO SPECIFICATIONS

Loudspeaker Type	Passive	Coaxial Point Source
Frequency Response		118Hz-18kHz (+/- 2dB) 90Hz-22kHz (-10dB)
Recommended Power Amplifier		200–300W @ 8 Ohms
Sensitivity (1 Watt @ 1 Meter)	LF HF Passive	86 dB SPL 88 dB SPL 86.7 dB SPL
Maximum Output		104.8 dB SPL
Drivers	LF HF	(1) 5 in. (127mm) (1) 0.75 in. (19.1mm) Dome Tweeter
Nominal Impedance		8 Ohms
Power Handling		100W Program / 400W Peak
Dispersion		120° H x 120° V (Conic)
Input Connection		(2) NL4 SpeakON Connectors & (1) 2-Position Terminal Strip

MECHANICAL SPECIFICATIONS

Enclosure	Shell Finish	15mm Baltic Birch Black Polyurea Coating
Rigging	Integral Rigging Points	(4) M10 x 1.5 Thread
Grille		Powder Coated Steel, Foam Backed
Dimensions	Height Width Depth	9.00 in. (228.6mm) 6.00 in. (152.4mm) 6.00 in. (152.4mm)
Weight		6 lbs. (2.7kg)
Shipping Weight		7 lbs. (3.2kg)

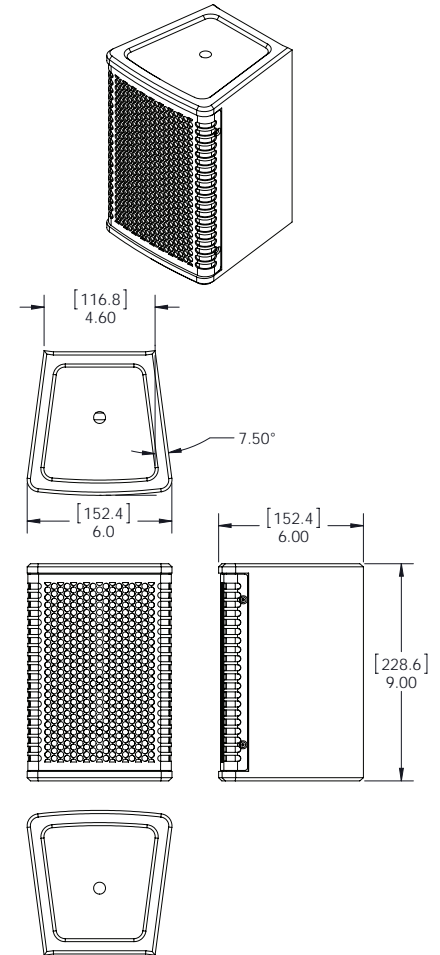

Note: All wattage figures are calculated using the rated nominal impedance.
Clair Brothers products are designed to perform optimally by utilizing factory recommended proprietary DSP settings.

5CB Terminal Strip Config.

Terminal Color	Use
Black	(-)
Red	(+)

5CB NL4 Pin Configuration

Pin	Use
1- / 1+	- / +
2- / 2+	- / +

ARCHITECT AND ENGINEER SPECIFICATIONS

The loudspeaker system shall be a two-way passive, coaxial point source loudspeaker cabinet featuring a total of (2) drivers. The front of the enclosure shall be fitted with a perforated, powder coated steel grille backed with foam. The system shall have an amplitude response of 118Hz to 18,000 Hz (+/- 2 dB). The loudspeaker system shall be loaded with one woofer; this low frequency driver shall be 5" nominal diameter with 1.7" voice coil diameter capable of handling 55W of power as per AES Standard. The high frequency section shall consist of a 0.75" diameter dome tweeter mounted on a 120°H x 120°V horn. The high frequency horn shall provide complete pattern control over the bandwidth. The high frequency horn shall be a constant directivity conic profile. The driver is capable of handling 10 watts (1 kHz to 20 kHz) of pink noise with a 6 dB crest factor for two hours (as per AES-1984 and ANSI S4.26-1984 standards). The enclosure shall be trapezoidal in geometry, constructed with 15mm Baltic birch and covered with a durable black polyurea coating. The dimensions shall be 9.0" high, 6.0" wide, and 6.0" deep. The 5CB enclosure shall incorporate four (4) integral rigging points, each with M10 x 1.5 thread for mounting bracket attachment. The system weight shall be 6 lbs (2.7kg). The loudspeaker system shall be the Clair Brothers 5CB loudspeaker.

Clair Brothers Asia | 143 Cecil Street, GB building Singapore 069542

Due to constant research, development and improvements all specifications are subject to change without notice.