



iS218-M Mobile Subwoofer



APPLICATIONS

Performing Arts Centers
Houses of Worship
Arenas/Auditoriums
Night Clubs
Cruise Ships
A/V Systems Support

FEATURES

Max Output 134 dB SPL
LF Devices: (2) 18 in. (457.2mm)
Integral Bimodal Rigging
Black Epoxy Mastic Finish
EP-4 Connectors

GENERAL DESCRIPTION

The iS218-M is the Mobile Low Frequency subwoofer extension of the Clair "i-Series" line array system designed for permanent installations. The cabinet features two 18 in. direct radiating drivers in a tuned dual-chamber, dual-reflex enclosure.

The iS218-M is designed with two complementary transducers and ports that minimize thermal power compression and air flow turbulence. The 18 in. transducers have weather-resilient cones with exceptional linear excursion. The result is a high power handling, high performance subwoofer that provides tightly controlled low-frequency extension.

The iS218-M's integral three-point rigging system allows several configurations. The iS218-M may be flown above the i212 line array, providing an aesthetically pleasing alternative to ground stacked subs beneath the array.

Clair Brothers combines amplification and proprietary DSP processing in portable racks for

all i-Series systems. Custom cabling for systems is available as well and can be pre-wired, labeled and delivered in road cases. For applications where flown rigging is not possible, the iS218-M can serve as a stacking base for the i212 line array speakers.

As with all Clair Brothers Speaker products, the iS218-M is constructed with the finest Baltic birch plywood and finished with a rugged exterior black epoxy mastic finish to withstand the most demanding conditions.

OPTIONS & ACCESSORIES

iS218-WR – Weather Resistant Model

iS218-i – Installation Model

Proprietary DSP + Amplification Rack Packages

Accessories: Ground Stack Rigging

Soft Cover and Dolly Transport

Custom Rigging

Custom Colors Available

iS218-M Mobile Subwoofer



AUDIO SPECIFICATIONS

Loudspeaker Type	Mobile	Dual Driver Subwoofer
Frequency Response (+/- 2dB)	Single Cabinet -10 dB Point	38Hz–180Hz 32Hz
Recommended Power Amplifier		2400–4000W @ 4 Ohms
Sensitivity (1 Watt @ 1 Meter)		103 dB SPL
Maximum Output	Cont. Peak	132.5 dB SPL 134 dB SPL
Drivers	LF	(2) 18 in. (457.2mm)
Nominal Impedance	LF	4 Ohms (2x 8 Ohms)
Power Handling	Nominal Peak	1400W 2800W
Input Connection	Standard	(2) EP-4 Connectors (1 Male, 1 Female)

MECHANICAL SPECIFICATIONS

Enclosure	Shell Finish	18mm Baltic Birch Black Epoxy Mastic
Grille		Perforated Steel, Foam Backed
Dimensions	Height Width Depth	25.20 in. (640.0mm) 42.04 in. (1067.8mm) 27.08 in. (687.8mm)
Weight		214 lbs. (97.1kg)
Shipping Weight		245 lbs. (111.1kg)

Note: All wattage figures are calculated using the rated nominal impedance.
Clair Brothers products are designed to perform optimally by utilizing factory recommended proprietary DSP settings.

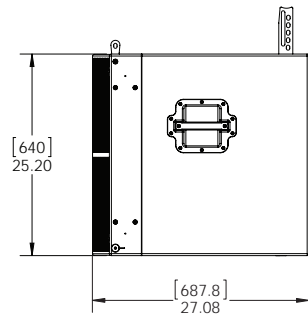
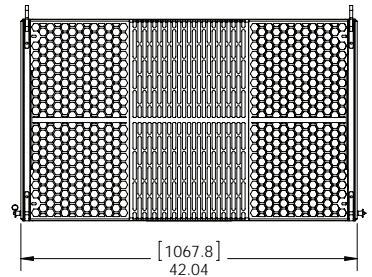
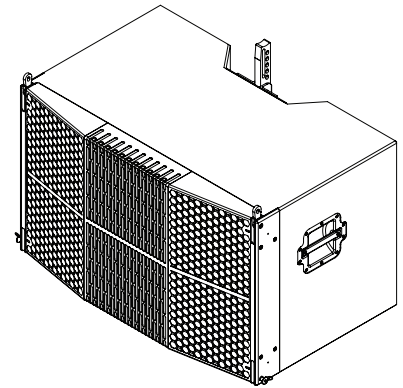

iS218-M EP-4 Pin Configuration

Pin	Use
1	Low 1 (-)
2	Low 1 (+)
3	Low 2 (-)
4	Low 2 (+)

ARCHITECT AND ENGINEERS SPECIFICATIONS

The loudspeaker shall be a mobile subwoofer system containing a total of two 18 in. drivers in a dual-chamber vented enclosure. Power handling capacity shall be 1400 watts RMS nominal and 2800 watts RMS peak. The low frequency drivers shall be 18 in. diameter capable of handling 700 watts of pink noise with a 6 dB crest factor for 8 hours (as per EIA RS-426-A standard). The pass-band frequency range shall be at minimum 38–180Hz with -10dB at 32Hz. The two 18 in. transducers shall have 4 in. diameter edge-wound copper ribbon voice coil with a well-vented magnet structure. The motor assembly shall have high thermal capacity and low thermal power compression characteristics. The enclosure shall be constructed of 18mm, 13-ply Baltic birch and be covered with a black epoxy mastic finish. The cabinet bracing shall be that of a gusset design providing uniform panel rigidity. The rigging system shall consist of i-Series compatible integrated rigging with provisions for both hanging and ground stacked applications. Dimensions shall be 25.20" high, 42.04" wide, and 27.08" deep. The system weight shall be 214 lbs. (97.1kg). The loudspeaker system shall be the Clair Brothers iS218-M speaker.

Clair Brothers Asia | 143 Cecil Street, GB building Singapore 069542

Due to constant research, development and improvements all specifications are subject to change without notice.