



12CX-P-60 Coaxial Loudspeaker



APPLICATIONS

Convention Centers
Educational Facilities
Dance Clubs
Race Tracks
Arenas / Stadiums

FEATURES

Coaxial, Horn-loaded
Two-Way Passive
Design with Grille
LF Device: 12 in. (304.8mm)
HF Device:
Voice Coil Diam 3 in. (76.2mm)
60° H x 60° V Coverage
Durable Polyurea Coating
2-Pos. Terminal Strip

GENERAL DESCRIPTION

Clair Brothers 12CX-P-60 loudspeaker has been designed as an ultimate hi-fidelity, large-format point source speaker. The frequency response is full range, 50Hz–16,000Hz, allowing for use for speech and music reproduction. A stand-out feature of 12CX-P-60 is its innovative horn technology. A coaxial horn arrangement provides conic constant directivity pattern control to both the 12" woofer as well as the 3" voice coil diameter compression driver. The 12CX-P-60 thus features a unique combination of two horns.

One horn responsible for directing low frequencies is a precision-machined solid birch plywood horn, measuring 21" at the mouth. The high frequency horn is comprised of three sections. The first section is a solid exponential throat followed by a conic constant directivity geometry made of heavy gauge perforated steel. The perforation patterns are geometrically optimized to allow proper crossover region behavior over the 60° polar coverage area between the upper midrange frequencies of the woofer with the compression driver.

This technology solves the common problem of horn shadowing with prior coaxial designs. The high frequency horn seamlessly joins with the low frequency horn as it extends toward the mouth.

12CX-P-60 is outfitted with two rigging plates integrated on the cabinet sides, each with one (1) 3/8"-16 thread, these are the attachment points for an installation mounting bracket (see Options).

The 12CX-P-60 is well suited for down-firing applications, such as large convention centers or high ceiling commercial spaces. In particular, its 23.5" x 23.5" square front face geometry is ideal for projecting through typical commercial drop ceilings. Please contact Clair Brothers for more information regarding coverage area planning and simulation.

OPTIONS & ACCESSORIES

12CX-60 – Active Model with 4-Pos. Terminal Strip
12CX-C-60, 12CX-CP-60 – Indoor Design [no grille]
Active & Passive Models
12CX-MB – Installation Mounting Bracket for 12CX
Custom Rigging Yokes
Custom Colors

I2CX-P-60 Coaxial Loudspeaker



AUDIO SPECIFICATIONS

Loudspeaker Type	Passive ¹	Coaxial, Horn-loaded Loudspeaker
Frequency Response (+/- 2dB)		50Hz–16kHz
Recommended Power Amplifier		1000–1200W @ 8 Ohms
Sensitivity (1 Watt @ 1 Meter) ²	LF	103 dB SPL
	HF	111 dB SPL
	Passive	106 dB SPL
Maximum Output	LF	131 dB SPL
	HF	133 dB SPL
	Passive	132 dB SPL
Drivers	LF	(1) 12 in. (304.8mm)
	HF	(1) Voice coil diameter 3 in. (76.2mm)
Nominal Impedance	LF	8 Ohms
	HF	8 Ohms
Power Handling	LF	350W Program / 700W Peak
	HF	80W Program / 160W Peak
Dispersion		60° H x 60° V (Conic)
Input Connections	12CX-P-60 Passive	2-Position Terminal Strip
	12CX-60 Active	4-Position Terminal Strip

MECHANICAL SPECIFICATIONS

Enclosure	Shell	18mm Baltic Birch
	Finish	Black Polyurea Coating
Grille		16 Gauge, Perforated Steel
Dimensions	Height	23.50 in. (596.9mm)
	Width	23.50 in. (596.9mm)
	Depth	18.00 in. (457.2mm)
Weight	Passive	97 lbs. (44.0kg)
	Active	90 lbs. (40.8kg)
Shipping Weight	Passive	105 lbs. (47.6kg)
	Active	98 lbs. (44.4kg)

¹ Standard product is Passive. [Active model may be ordered as an option.]

² Sensitivity measured in half space, average SPL over rated bandwidth.

Note: All wattage figures are calculated using the rated nominal impedance.

Clair Brothers products are designed to perform optimally by utilizing factory recommended proprietary DSP settings.

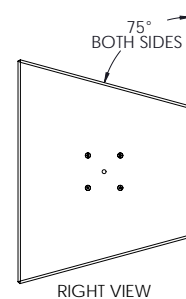
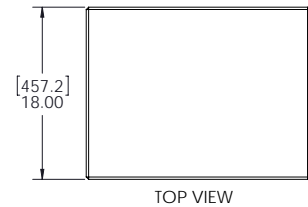
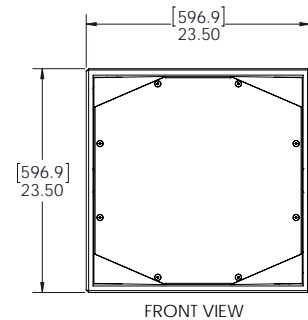
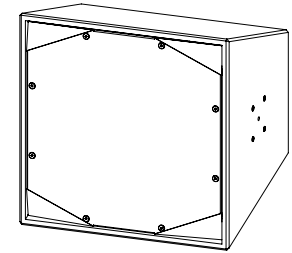

ARCHITECT AND ENGINEER SPECIFICATIONS

The loudspeaker shall be a two-way passive system [or active, if specified] featuring a total of two (2) drivers. The low frequency section shall consist of one 12" driver capable of handling 350 watts of pink noise with a 6 dB crest factor for eight hours (as per EIA RS-426-A standard). The 12" woofer shall be horn-loaded onto a conic horn constructed wholly of solid birch plywood, structurally designed to minimize resonances in the device passband. The low frequency horn shall provide controlled directivity defined by -6dB at coverage angle to approximately 400 Hz. The high frequency section shall consist of a 3" voice coil diameter compression driver mounted on a 60°H x 60°V horn. The high frequency horn shall provide complete pattern control over the bandwidth. The high frequency horn shall be a constant directivity conic profile featuring acoustic lowpass boundary sections whose lowpass function varies according to the angle relative to the low frequency transducer behind it. The driver is capable of handling 80 watts (1 kHz to 10 kHz) of pink noise with a 6 dB crest factor for two hours (as per AES-1984 and ANSI S4.26-1984 standards). The enclosure shall be trapezoidal in geometry, constructed with 18mm, 13-ply Baltic birch and covered with a durable black polyurea coating. The dimensions shall be 23.50" high, 23.50" wide, and 18.00" deep. The 12CX-P-60 enclosure shall incorporate two (2) integral rigging plates, each with one (1) 3/8"-16 thread for mounting bracket attachment. The passive system weight shall be 97 lbs (44.0kg) [90 lbs. (40.8kg) for active]. The loudspeaker system shall be the Clair Brothers 12CX-P-60, or 12CX-60, loudspeaker.

12CX-P-60 Terminal Strip Config.

Terminal Color	Use
Black	(-)
Red	(+)

12CX-60 Terminal Strip Configuration

Terminal Color	Use
Black	Low (-)
Red	Low (+)
Black	High (-)
White	High (+)

Clair Brothers Asia | 143 Cecil Street, GB building Singapore 069542

Due to constant research, development and improvements all specifications are subject to change without notice.